

Arguing About Cases as Practical Reasoning

Katie Atkinson, Trevor Bench-Capon and Peter McBurney
Department of Computer Science
University of Liverpool
Liverpool L69 3BX, UK

{k.m.atkinson,tbc,p.j.mcburney}@csc.liv.ac.uk

ABSTRACT

In this paper we apply a general account of practical reasoning to arguing about legal cases. In particular, we describe how the reasoning in one very well known property law case can be reconstructed in terms of our account. We begin by summarising our general approach which uses instantiations of an argumentation scheme to provide presumptive justifications for actions, and critical questions to identify arguments which attack these justifications. These arguments and attacks are organised into argumentation frameworks to identify the status of individual arguments. Different beliefs about, and perspectives on, the issue are represented by different agents based on the Belief-Desire-Intention model, and conditions under which these agents may advance justifications and attack them are described. We model the different views of our case in these terms, describe the resulting argumentation frameworks, and relate them to the original majority and dissenting opinions. We contend that this approach both shows the worth of the general approach and its applicability to the legal domain.

1. INTRODUCTION

One of the first projects in AI and Law, the TAXMAN project [19] of McCarty and Sridharan (most recently reported in [18]) had as its goal providing a computational means of generating the majority and minority opinions in a celebrated tax law case, *Eisner vs Macomber*, 252 U.S. 189 (1920). The work described in this paper is in that tradition: here we will present a computational means of simulating the opinion and dissent in perhaps the most famous case in property law, *Pierson vs Post*, 3 Cai R 175 2 Am Dec 264 (Supreme Court of New York, 1805), said to have been read by (or at least assigned to) every law student in America. As a bonus we will also consider some additional arguments that have arisen in subsequent commentary and discussion.

Our approach builds on work we have developed relating to debates concerning practical reasoning - reasoning about what should be done. In [15] we argued that reasoning about legal cases should be seen as a species of practical reasoning, and proposed an argument scheme for practical reasoning. Instantiating this argument scheme provides a presumptive justification for an action,

Permission to make digital or hard copies of all or part of this work for personal or classroom use is granted without fee provided that copies are not made or distributed for profit or commercial advantage and that copies bear this notice and the full citation on the first page. Copyrights for components of this work owned by others than ACM must be honored. Abstracting with credit is permitted. To copy otherwise, to republish, to post on servers or to redistribute to lists, requires prior specific permission and/or a fee.
ICAIL '05, June 6-11, 2005, Bologna, Italy.
Copyright 2005 ACM 1-59593-081-7/05/0006 ...\$5.00.

and that paper also identified the ways in which this presumption could be challenged. The argument scheme can be seen as a refinement of the *sufficient condition scheme* for practical reasoning proposed in [26], and the attacks on arguments of this form can be construed in terms of critical questions directed against the argument [3]. To make the process of practical reasoning computational, we have provided definitions and preconditions for instantiating the scheme and challenging instantiations of the scheme for use in multi agent systems based on the Belief-Desire-Intention (BDI) model [2]. The presumptive arguments and attacks on them are resolved through organisation into a Value Based Argumentation Framework (VAF)[8], enabling the calculation of the dialectical status of the various arguments with respect to the participants in the debate. This technique has also been applied in a medical application [4]. The key points of this work will be recapitulated in section 2. The main contribution of this paper is to bring together our earlier work so as to provide a thoroughly worked out example of the application of this approach to law.

Our approach will be to model the various participants in the debate as different agents. We see the disagreements as grounded in divergent beliefs, goals and values, and therefore will use different agents to represent the different views that can be brought to bear on the problem. Section 3 will describe the case and the agents we will use.

In section 4 we will represent the beliefs, desires and values of the four agents pertinent to the problem and generate the arguments that these agents can form on the basis of this knowledge, and show the relations between these arguments as a set of VAFs. In section 5 we will relate this to the opinions in the original decision. Finally in section 6 we will offer some concluding remarks.

2. GENERAL APPROACH TO PRACTICAL REASONING WITH AGENTS

Our starting point is to see deciding a case as an *action* to be justified, rather than the recognition of a property of a case which enables it to be classified. We base reasoning about such decisions on a general argument scheme designed to provide a presumptive justification for an action. This scheme extends a similar scheme of Walton [26] by unpacking his notion of a goal into three elements, the state of affairs brought about by the action, the goal (the desired features in that state of affairs) and the value (the reason why those features are desirable). The scheme may be expressed as:

AS1: In the current circumstances R
Action A should be performed
To bring about new circumstances S
Which will realise goal G
And promote value V

This presumptive justification may be attacked in a large variety of ways, as described in [15], as the various elements and the connections between them are open to question, and additionally there may be alternative possible actions, and side effects of the proposed action. We will define the attacks used in this paper in section 2.1.

The computational setting for our approach is a multi agent system, in which the agents form intentions based on their beliefs and desires. This is essentially the standard BDI agent model [27], except that we make a small extension by associating each desire with a value, the reason why it is desirable.

We use the following definitions. Our general account allows for different degrees of belief in a proposition and different likelihoods of an action achieving an effect. Although in this application we do not use these different degrees of assurance, we follow the general account here.

2.1 Definitions

Definition 1: The Beliefs of an Agent. The beliefs of an Agent J is a four tuple $\langle W_J, A_J, D_J, V_J \rangle$ where,

W_J represents beliefs of Agent J about the world;
 A_J represents beliefs of Agent J about actions;
 D_J represents beliefs about the desires of Agent J;
 V_J represents beliefs about the values of Agent J;

Definition 2: Beliefs about the World. The beliefs about the world of Agent J is a set of triples $\langle p, cert_{pJ}, t \rangle$ where,

p is a proposition; $cert_{pJ} = -1 \leq cert_{pJ} \leq 1$; t is a time.

We interpret this as J has $cert_{pJ}$ regarding p at time t . If $cert_{pJ} = -1$, J believes p to be definitely false, if $cert_{pJ} = 1$, J believes p to be definitely true, and if $cert_{pJ} = 0$, J has no opinion as to the truth of p .

Let M denote the set of all agents in the system and T the set of all times.

The set P denotes the set of all p such that $\langle p, cert_{pJ}, t \rangle \in W_J$ for some agent $J \in M$ and some time $t \in T$.

Definition 3: Beliefs about Actions. The beliefs about action of Agent J is a set of triples $\langle a, Pre_{aJ}, Post_{aJ} \rangle$ where,

$action a$ is an action; Pre_{aJ} is a set of pairs $\langle p, threshold_{pJ} \rangle$ and $Post_{aJ}$ is a set of pairs $\langle p, truth_{pJ} \rangle$, $-1 \leq threshold_{pJ} \leq 1$, and $-1 \leq truth_{pJ} \leq 1$.

Pre_{aJ} is a set of preconditions for $action a$ recognised by agent J. The interpretation is that J believes that $action a$ can be performed at t if all elements of Pre_{pJ} are satisfied with respect to W_J at t .

$\langle p, threshold_{pJ} \rangle$ is satisfied with respect to W_J if $\langle p, cert_{pJ}, t \rangle$ and if $threshold_{pJ} > 0$, then $cert_{pJ} \geq threshold_{pJ}$, else if $threshold_{pJ} < 0$, $cert_{pJ} \leq threshold_{pJ}$. J believes that if $action a$ is performed at t , then for all $\langle p, truth_{pJ} \rangle \in Post_{aJ}$, $\langle p, truth_{pJ}, t+1 \rangle$ will be an element of W_J .

W_{Ja} is the state of the world that J believes will result from performing $action a$.

Additionally, J may *assume* that $action a$ can be performed at t if all elements of Pre_{aJ} can be *assumed to be satisfied* with respect to W_J at t . $\langle p, threshold_{pJ} \rangle$ can be assumed satisfied with respect to W_J if $\langle p, cert_{pJ}, t \rangle$ and if $threshold_{pJ} > 0$, then $cert_{pJ} \geq 0$ and if $threshold_{pJ} < 0$, $cert_{pJ} \leq 0$.

The set A denotes the set of all actions such that $\langle a, Pre_{aJ}, Post_{aJ} \rangle \in A_J$ for some agent $J \in M$.

Definition 4: Desires of an Agent. The desires of an Agent J is a set of pairs $\langle d, Cond_{dJ} \rangle$ such that,

d is a desire and $Cond_{dJ}$ is a set of pairs $\langle p, threshold_{pJ} \rangle$. The interpretation is that J believes that d is satisfied at t if $Cond_{dJ}$ is satisfied with respect to W_J at t . The notions of satisfaction and assumed satisfaction for $Cond_{dJ}$ is the same as that for Pre_{aJ} .

The set D denotes the set of all desires such that $\langle d, Cond_{dJ} \rangle \in D_J$ for some agent $J \in M$.

Definition 5: Values of an Agent. The values of an Agent J is a set of triples $\langle v, d, prom_{vJ} \rangle$ such that,

v is a value,
 d is a desire,
 $prom_{vJ}$ a number $-1 \leq prom_{vJ} \leq 1$, representing the degree to which the satisfaction of d promotes v . A negative number indicates that the value is demoted, that the action has an inverse impact with respect to the value.

The set V denotes the set of all values such that $\langle v, d, prom_{vJ} \rangle \in V_J$ for some agent $J \in M$.

Definition 6: Let $satA(Formula, W_J)$ be true if Formula can be assumed to be satisfied with respect to W_J .

Let $satS(Formula, W_J)$ be true if Formula can be satisfied with respect to W_J .

Now J has a presumptive argument for $action a$ at time t if:

there is an $\langle a, Pre_{aJ}, Post_{aJ} \rangle \in A_J$ such that:
 $satA(Pre_{aJ}, J)$ at t ;
 $satA(Cond_{dJ}, J)$ at $t+1$ and
 $Cond_{dJ}$ will be satisfied at $t+1$ with respect to W_J ;
there is a $\langle v, d, prom_{vJ} \rangle$, such that $prom_{vJ} > 0$.

The position is expressed as:

In circumstances r , where each $r \in R$ is the first term,
in each element of Pre_{aJ} ,
Performing $action a$,
Will result in s , where each $s \in S$ is the first term in
each element of $Post_{aJ}$,
Which will realise d ,

Which promotes v .

On the basis of these definitions we can state the following pre-conditions for attacking such presumptive arguments. Each of these attacks may be associated with a critical question, as described in [3]. For each attack we give the critical question from which it derives and a natural language expression of the attack. The complete set of preconditions for attacks is in [2]: here we give only those used subsequently in the paper.

Source CQ: Are the believed circumstances true?

Attack 1a: *Pre-conditions for A_K to make an attack:*

$\text{satA}(\text{Pre}_{aK}, W_K)$ and,
not $\text{satS}(\text{Pre}_{aK}, W_K)$.

Argument: p may not be true.

Attack 1b: *Pre-conditions for A_K to make an attack:*

not $\text{satA}(\text{Pre}_{aK}, W_K)$.

Argument: p is not true.

Source CQ: Assuming the circumstances are true, does the action have the stated consequences?

Attack 2a: *Pre-conditions for A_K to make an attack:*

$\text{satA}(\text{Post}_{aK}, W_K)$ and,
not $\text{satS}(\text{Post}_{aK}, W_K)$.

Argument: action a may not have the desired consequences.

Attack 2b: *Pre-conditions for A_K to make an attack:*

not $\text{satA}(\text{Post}_{aK}, W_K)$.

Argument: action a will not have the desired consequences.

Source CQ: Does the goal realise the value intended?

Attack 4a: *Pre-conditions for A_K to make an attack:*

$\langle v, d, \text{prom}_{vK} \rangle$ and,
 $\text{prom}_{vK} \leq 0$.

Argument: the goal may not promote the value.

Attack 4b: *Pre-conditions for A_K to make an attack:*

$\langle v, d, \text{prom}_{vK} \rangle$ and,
 $\text{prom}_{vK} < 0$.

Argument: the goal will not promote the value.

Source CQ: Are there alternative ways of realising the same goal?

Attack 6: *Pre-conditions for A_K to make an attack:*

$\text{satA}(\text{Pre}_{bK}, W_K)$ and,
 $\text{satA}(\text{Cond}_{dK}, W_{Kb})$ and $b \neq a$.

Argument: there is an alternative action which will realise the same goal.

Source CQ: Are there alternative ways of promoting the same values?

Attack 7a: *Pre-conditions for A_K to make an attack:*

$\text{satA}(\text{Pre}_{bK}, W_K)$ and,
for some $e, e \neq d$, $\text{satA}(\text{Cond}_{eK}, W_{Kb})$ and $b \neq a$ and,
 $\langle v, e, \text{prom}_{vK} \rangle$ and,
 $\text{prom}_{vK} > 0$.

Argument: there is an alternative action, satisfying an alternative desire, which will promote the value.

Attack 7b: *Pre-conditions for A_K to make an attack:*

$\text{satA}(\text{Cond}_{eK}, W_{Ka})$, $e \neq d$ and,
 $\langle v, e, \text{prom}_{vK} \rangle$ and,
 $\text{prom}_{vK} > 0$.

Argument: action a has a side effect which satisfies an alternative desire, which promotes the value.

Source CQ: Does doing A have a side effect which demotes the value V ?

Attack 8: *Pre-conditions for A_K to make an attack:*

$\text{satA}(\text{Cond}_{eK}, W_{Ka})$, $e \neq d$ and,
 $\langle v, e, \text{prom}_{vK} \rangle$ and,
 $\text{prom}_{vK} < 0$.

Argument: action a has a side effect which satisfies an alternative desire, which demotes the value.

Source CQ: Would doing A promote some other value?

Attack 10: *Pre-conditions for A_K to make an attack:*

$\text{satA}(\text{Cond}_{eK}, W_{Ka})$, $e \neq d$ and,
there is a $w, w \neq v$ such that $\langle w, e, \text{prom}_{wK} \rangle$ and,
 $\text{prom}_{wK} > 0$.

Argument: action a has a side effect which satisfies an alternative desire, which promotes some other value.

Source CQ: Does doing A preclude some other action which would promote some other value?

Attack 11a: *Pre-conditions for A_K to make an attack:*

$\text{satA}(\text{Pre}_{aK}, W_K)$ and,
 $\text{satA}(\text{Cond}_{eK}, W_{Kb})$, $e \neq d$ and,
there is a $w, w \neq v$ such that $\langle w, e, \text{prom}_{wK} \rangle$ and,

$\text{prom}_{wK} > 0$ and,
not $\text{satA}(\text{Pre}_{aK}, W_{Kb})$ and,
not $\text{satA}(\text{Pre}_{bK}, W_{Ka})$.

Argument: doing *action a* precludes some other action which would promote some other value.

Source CQ: Are the particular aspects of S represented by G possible?

Attack 15: *Pre-conditions for A_K to make an attack:*
 $\langle d, \text{Cond}_{dK} \rangle \notin D_K$.

Argument: there is no such desire.

Source CQ: Is the value proposed indeed a legitimate value?

Attack 16: *Pre-conditions for A_K to make an attack:*
 $\langle v, d, \text{prom}_{vK} \rangle \notin V_K$.

Argument: there is no such value.

Now given a set of agents and a situation in which an action must be chosen we can first instantiate a number of presumptive justifications for each agent, and then see which attacks the agents can make on these justifications. The result will be a set of arguments and a set of attack relations between them, providing the key elements for an argumentation framework [14]. Moreover, since the arguments produced by instantiating AS1 are associated with values, we can see this as a VAF [8], and use the procedures in that paper to calculate the dialectical status of the arguments with respect to the different audiences represented by the different agents.

This process will be illustrated by a detailed working through of our example in section 4.

3. REPRESENTING OUR CASE

We begin by giving a summary of the decision in *Pierson vs Post*.¹ The language used is appealingly extravagant and may in part account for the popularity of the case in teaching. It begins with a statement of the facts. After giving the procedural context the facts are stated as:

Post, being in possession of certain dogs and hounds under his command, did, upon a certain wild and uninhabited, unpossessed and waste land, called the beach, find and start one of those noxious beasts called a fox, and whilst there hunting, chasing and pursuing the same with his dogs and hounds, and when in view thereof, Pierson, well knowing the fox was so hunted and pursued, did, in the sight of Post, to prevent his catching the same, kill and carry it off. A verdict having been rendered for the plaintiff below, the defendant there sued out a certiorari and now assigned for error, that the declaration and the matters therein contained were not sufficient in law to maintain an action.

¹The text of this decision is available on a number of websites e.g. <http://www.saucyintruder.org/pages/pierson.html>

The opinion of the court was delivered by Tompkins, J. The decision can be seen as a sequences of parts, to which we will give identifying numbers Tn for later reference. He begins by stating the question to be determined (T1):

The question submitted by the counsel in this cause for our determination is, whether Lodowick Post, by the pursuit with his hounds in the manner alleged in his declaration, acquired such a right to, or property in, the fox, as will sustain an action against Pierson for killing and taking him away?

The next paragraph (T2) discusses a number of authorities on the question of whether a wild animal can be owned other than through bodily possession, or at least mortal wounding. Tompkins concludes:

The foregoing authorities are decisive to show that mere pursuit gave Post no legal right to the fox, but that he became the property of Pierson, who intercepted and killed him.

He then (T3) dismisses a number of previous, mostly English cases as irrelevant because they:

... have either been discussed and decided upon the principles of their positive statute regulations, or have arisen between the huntsman and the owner of the land upon which beasts ferae naturae have been apprehended ...

He next returns to his authorities (T4), and whilst being inclined to accept that wounding would constitute possession, states

The case now under consideration is one of mere pursuit, and presents no circumstances or acts which can bring it within the definition of occupancy by Puffendorf, or Grotius, or the ideas of Barbeyrac upon that subject.

Next (T5) he considers a precedent case, *Keeble vs Hickergill*, 11 East 574, 103 Eng Rep 1127 (Queen's Bench, 1707). This case had been cited as an example of where malicious interference in hunting was deemed to provide a reason for remedy. Tompkins distinguished this both on the grounds that Keeble suffered economic loss, and that the animals were on his own land:

... the action was for maliciously hindering and disturbing the plaintiff in the exercise and enjoyment of a private franchise; in the report of the same case, (3 Salk. 9) Holt, Ch. J., states, that the ducks were in the plaintiff's decoy pond, and so in his possession, from which it is obvious the court laid much stress in their opinion upon the plaintiff's possession of the ducks, *ratione soli*.

He then (T6) motivates his decision by a desire that the law should be clear:

We are the more readily inclined to confine possession or occupancy of beasts ferae naturae, within the limits prescribed by the learned authors above cited, for the sake of certainty, and preserving peace and order in society. If the first seeing, starting, or pursuing such animals, without having so wounded, circumvented or ensnared them, so as to deprive them of their natural liberty, and subject them to the control of their pursuer, should afford the basis of actions against others for intercepting and killing them, it would prove a fertile source of quarrels and litigation.

Finally (T7) he concludes by saying that even if any malice was involved this “act was productive of no injury or damage from which a legal remedy can be applied.”, suggesting that such damage needs to be economic to provide any remedy: the law cannot compensate for loss of sport.

The overall thrust of this decision seems to be that the law is rather clear as it stands: the only question is ownership, and that ownership in a wild animal cannot be acquired through mere pursuit. Moreover, where there is no measurable damage, no legal remedy is appropriate.

Livingston, J. then gives his dissent. Again, we number its parts Ln for later reference. He (L1) agrees that there is a single question: whether pursuit of the fox gave “such an interest in the animal, as to have a right of action against another”. He then says (L2) that such cases should not be brought to court but arbitrated by sportsmen (ignoring the bias in favour of Post that such a tribunal would have). He then (L3) argues that hunting should be encouraged as the depredation of foxes “on farmers and on barn yards have not been forgotten; and to put him to death wherever found, is allowed to be meritorious, and of public benefit” and that no one would hunt if their sport were regularly spoiled by interventions such as that of Pierson. He says (L4) the authorities cited are old, and that the court is able to state a new law: “if men themselves change with the times, why should not laws also undergo an alteration?” In any event the authorities do not require bodily possession and so a finding for Post would be compatible with them. The crux of his argument (L5) is that

... the interest of our husbandmen, the most useful of men in any community, will be advanced by the destruction of a beast so pernicious and incorrigible, we cannot greatly err, in saying, that a pursuit like the present, through waste and unoccupied lands, and which must inevitably and speedily have terminated in corporal possession, or bodily seisin, confers such a right to the object of it, as to make any one a wrong-doer, who shall interfere and shoulder the spoil.

In sum: since fox hunting is of public benefit because it assists farmers it should be encouraged by giving the sportsman protection of the law.

The arguments of Tompkins and Livingston are at rather different levels. Whereas Tompkins confines himself to discussion in terms of legal concepts - which to him clearly provide no basis for remedy, Livingston talks mainly about the real world, and whether fox hunting is desirable or not, and argues that if it is, the legal concepts should be interpreted so as to provide a remedy.

In our reconstruction of the arguments we will use two different agents to represent Tompkins and Livingston. We will refer to these agents as T and L respectively. We will also use two additional agents to make points not raised in the decision, but which have emerged in subsequent debate.

The first disputes Livingston’s claims about the benefit of hunting. Those familiar with the novels of Anthony Trollope will know that fox hunting features quite prominently. In one of his novels, *The American Senator* [23], a major sub-plot concerns a farmer who poisons a fox. This outrages the hunting community, since they wish to preserve foxes for their sport. It is quite clear that Trollope, who is a fervent pro-hunter, recognises that but for hunting, foxes would be rapidly eliminated by farmers through the more efficient pest control methods of snaring, poisoning, gassing and shooting. Indeed if, in Livingston’s words, “to put [a fox] to death wherever found, is allowed to be meritorious, and of public benefit”, it is clear that hunting should be discouraged, since where

hunting is encouraged these more efficient methods are subject to social stigma. Trollope, however, does wish to encourage hunting on its intrinsic merits: he would therefore wish the law to condemn Pierson’s malicious interference in the sport. We shall call this agent A, for Anthony.

The final agent also disputes whether hunting should be encouraged. A recent Act of Parliament means that fox hunting in the traditional manner will soon be illegal in the UK. The argument here has been solely based on the cruelty of hunting: shooting and gassing are preferred on grounds of humaneness rather than efficiency. On such a view Pierson is acting in a laudable manner, by saving the fox pain, and it is the actions that discourage hunting that should be encouraged. We will call this agent B, after Tony Banks, MP, who was a vocal opponent of hunting during this debate.

In the next section we will instantiate these four agents with the appropriate beliefs, desires and values, in accordance with the definitions given in section 2.

4. GENERATING THE ARGUMENTS

We begin by identifying desires and values. From definition 4 we need to identify a set of desires for the agents, and give conditions under which the agents will accept that these desires are realised. Definition 5 requires us to associate these desires with a value, and a degree to which the satisfaction of the desire promotes the value. Tables 1 and 2 list the set of desires, conditions, values and degrees that we will use. Since we do not consider varying degrees of promotion we only use 1 where the value is promoted and -1 where it is demoted. Table 1 gives the initial desires and Table 2 those that may be derived in the course of the debate. Desires common to all our agents are shown in bold.

There are 4 agents in the situation: Livingstone(L), Tomkins(T), Tony Banks(B) and Anthony Trollope (A). Each agent has different desires they wish to achieve and has different values they wish to promote, though many of these will be in common. From Table 1 all agents ascribe to desires 1 and 2 and 3. Agents T, L and A do not accept desires 8 and 9 as they do not regard ‘reducing animal suffering’ as promoting ‘humaneness’, animal suffering not being a consideration in their pre-animal rights way of thinking. Additionally, agent T does not accept desires 4 to 7 as he does not regard ‘public benefit’ as a value which the law should recognise. The agents may adopt the derived desires in the course of their reasoning.

We use nine propositions about the world to describe the given situation and these are as follows:

- F1: Post was in pursuit of the fox.
- F2: Post had neither captured nor wounded the fox (he had no possession of the fox).
- F3: Pierson killed the fox to spoil Post’s sport (Pierson had malicious intent).
- F4: Foxes kill livestock.
- F5: Encouraging hunting will reduce the number of foxes.
- F6: Reducing the number of foxes protects the livestock of farmers.
- F7: If hunting is discouraged, needless animal suffering is not inflicted.

Our agents differ quite widely as to the facts. Each agent ascribes to these propositions as shown in Table 3 with 1 representing belief

Table 1: Possible Desires and Values in the Initial Situation

No.	Desire	Value	Promoted	Cond _d
1	Clear Law	Less Litigation	1	Ownership, Plaintiff No ownership, No possession
2	Unclear Law	Less Litigation	-1	Ownership, No Possession. No Ownership, Plaintiff. No Ownership, Possession.
3	Trade Restricted	Economic Benefit	-1	Malicious Intent, Productive Activity, Defendant
4	Malice Condemned	Public Benefit	1	Malicious Intent, Plaintiff
5	Malice Condoned	Public Benefit	-1	Malicious Intent, Defendant
6	Less Threat to Others	Public Benefit	1	Fewer Foxes Farmers Protected
7	More Threat to Others	Public Benefit	-1	−Fewer Foxes −Farmers Protected
8	More Suffering	Humaneness	-1	−Reduced Animal Suffering
9	Less Suffering	Humaneness	1	Reduced Animal Suffering

Table 2: Derivable Desires and Values

No.	Desire	Value	Promoted	Cond _d
10	Hunting Encouraged	Public Benefit	1	Ownership, Pursuit
11	Hunting Discouraged	Humaneness	1	−Pursuit, No ownership

in the proposition, -1 representing disbelief in the proposition and U representing unknown to show that the agent has subscribed to neither belief nor disbelief in the proposition.

Based upon the beliefs and desires given in the above tables, each agent can provide one or more instantiation of AS1. The figures presented below give three argumentation frameworks to show the views of the agents at three different levels: the level of facts about the world, at which desires are derived; the level at which the legal system connects with the world to achieve these desires, and at the level of pure legal concepts. These levels are familiar from other work in AI and Law, and are explicit in the functional ontology of Valente [24], and some discussions of expert systems within the logic programming paradigm, such as [5]. Conclusions at lower levels will be used as premises at higher levels. We present each of the argumentation frameworks followed by the instantiations of AS1 and any attacks that can be made on these instantiations using the preconditions in section 2. In the figures, nodes represent arguments. They are labelled with an identifier, the associated value, if

Table 3: Propositions about the World

Agent	F1	F2	F3	F4	F5	F6	F7
L	1	1	1	1	1	1	U
T	1	1	1	1	U	1	U
B	1	1	-1	U	U	U	1
A	1	1	U	1	-1	U	1

any, and on the right hand side, the agent introducing the argument. Arcs are labelled with the number of the attack they represent. We then summarise what can be deduced from the framework in order to proceed to the next level in the argument.

Below is the argumentation framework for level 1 schemes:

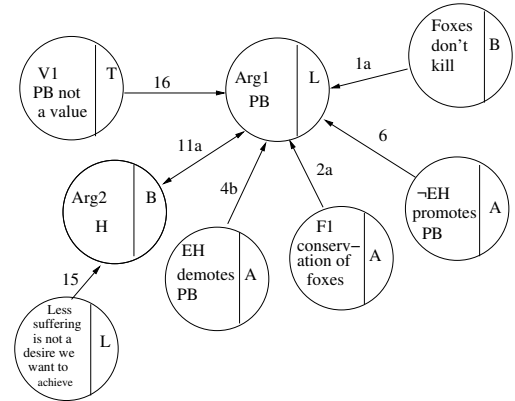

Figure 1. Level 1: Arguments about the world.

This argumentation framework is constructed from the following arguments. We omit S, the circumstances resulting from the performance of the action since G represents the relevant subset of these circumstances. S is of importance only if we need to distinguish what results from an action, from the desires that it satisfies.

Arg1

- R1: Where foxes kill livestock, encouraging hunting leads to fewer foxes and fewer foxes means farmers are protected
- A1: encourage fox hunting
- G1: as fewer foxes and farmers protected
- V1: promotes public benefit.

Agent L puts forward Arg1 and this is attacked by Arg2 using attack 11a which is put forward by agent B:

Arg2

- R2: Where fox hunting is cruel
- A2: discourage fox hunting
- G2: as reduced animal suffering
- V1: promotes humaneness.

This argument is mutually attacked by agent L's original statement made in Arg1 but agent L can also attack it using attack 15 which states that L does not believe that 'reduced animal suffering' is a desire that we want to achieve. Agent B can also make a second attack by disputing the fact 'foxes kill' using attack 1a. Agent A can also attack agent L's Arg1 by using 3 different attacks; attack 4b, 2a or 6. Finally, agent T can make attack 16 on Arg1 by stating that 'public benefit' is not a value we should be trying to promote.

From the argumentation framework in Figure 1 agent L can, by making suitable choices about preferences, deduce that hunting

should be encouraged and agents B and A can deduce that hunting should be discouraged, using their own preferences. T, by accepting L's argument against Arg2, need subscribe to neither argument, and so derives no additional desires from this level of the debate.

We can now move on to the next level, giving the argumentation framework shown below in Figure 2:

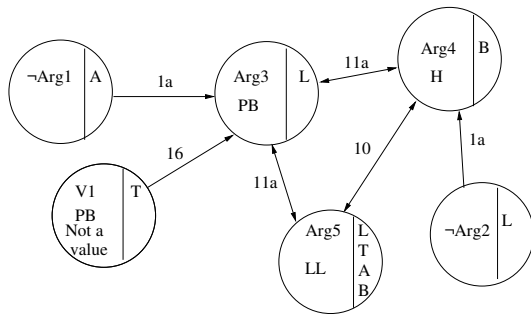

Figure 2. Level 2: Linking to legal concepts.

This argumentation framework is constructed from the following instantiations of AS1:

Arg3

- R3: Where there is pursuit and fox hunting is to be encouraged
- A3: find ownership established
- G3: as hunting encouraged
- V3: promotes public benefit.

Arg4

- R4: Where there is pursuit and fox hunting is to be discouraged
- A4: find no ownership
- G4: as hunting discouraged
- V4: promotes humaneness.

Arg5

- R5: Where there is no possession
- A5: find ownership not established
- G5: as finding no ownership where no possession
- V5: promotes less litigation.

Agent L puts forward Arg3. Firstly, this is attacked by agents T and B using attack 1a, stating that they do not believe Arg1 from the previous framework to be true. Agent T also attacks Arg3 by using attack 16 which states that 'public benefit' is not a value. There is then a 3-cycle of attacks: all agents using attack 11a to attack Arg3 with Arg5. This is itself attacked by Arg3. The next attack in the cycle is also a mutual one put forward by agent B using attack 10 to state Arg4. Arg4 also mutually attacks Arg3 using attack 11a, which completes the 3-cycle. However, Arg4 is attacked by agent L using attack 1a stating that he does not believe that Arg2 from the previous framework holds.

Figure 2 debates whether or not ownership is to be attributed on these facts. L uses Arg3 to say that ownership should be attributed, relying on his view of what the facts about foxes are from level 1. L uses a preference for public benefit over less litigation to avoid defeat by attack 5. He attacks Arg6, the favoured argument of B, because he does not accept Arg2 from level 1 since humaneness is not among his values. The attack of A can be ignored by L as it turned on a factual disagreement in the previous level. All except L agree that Arg3 is defeated, although for different reasons,

and so accept Arg5. L accepts Arg5, but believes that its force is insufficient to defeat Arg3. We can now move on to the top level arguments, giving the argumentation framework shown below in Figure 3:

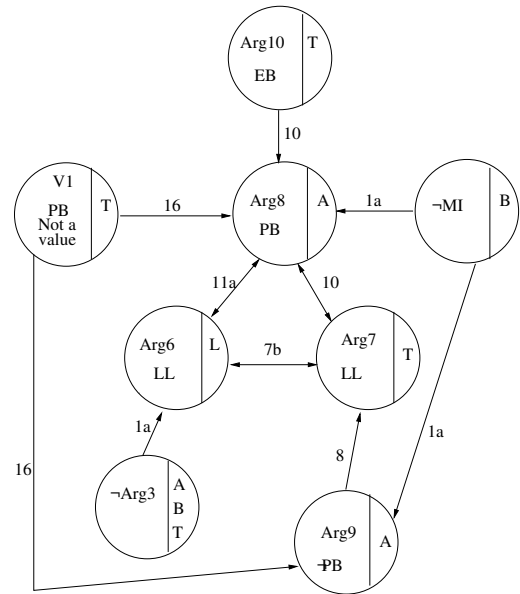

Figure 3. Level 3: Arguments in terms of legal concepts.

This argumentation framework is constructed from the following argument schemes:

Arg6

- R6: Where there is ownership
- A6: find for plaintiff
- G6: as finding for plaintiff with ownership
- V6: promotes less litigation.

Arg7

- R7: Where there is no ownership
- A7: find for defendant
- G7: as finding for defendant where there is no ownership
- V7: promotes less litigation.

Arg8

- R8: Where there is malicious interference by defendant
- A8: find for plaintiff
- G8: as finding for plaintiff where there is malicious interference
- V8: discourages immoral behaviour.

Arg9

- R9: Where there is malicious interference by defendant
- A9: do not find for defendant
- G9: as finding for defendant where there is malicious interference
- V9: discourages moral behaviour.

Arg10

- R10: Given the facts of Keeble
- A10: do not find for defendant
- G10: as finding for defendant where there is malicious interference and productive activity

V10: demotes economic benefit.

Agent L puts forward Arg6. This is immediately attacked by all of T, B and A who, for their different reasons, did not accept Arg3 from the previous framework and therefore deny its premise. Next, agent A, who wishes to find for Post not on grounds of the protection of farmers but to condemn Pierson's interference in Post's sport, uses attack 11a to state Arg8 (which is mutually attacked by Arg6), but this is in turn attacked by agent T's attack 16 and also by agent B's attack 1a stating that he does not believe that the interference was malicious. Agents T and B can make attacks 10 and 7b on Arg8 and Arg6 respectively by stating Arg7, which is their main argument, based on their acceptance of Arg5 at the previous level. This creates a 3-cycle of attacks between schemes Arg6, Arg7 and Arg8. However, Arg7 is then attacked by agent A using attack 8 which states Arg9. Like Arg8 this can be attacked by the two existing nodes in which agent T uses attack 16 to say 'public benefit' is not a value and agent B uses attack 1a to state that he does not believe that there was malicious interference.

The one precedent explicitly cited in the decision is *Keeble*. The role of *Keeble* is to provide support for Arg8, in the manner described in [15]. This, however, can be attacked using attack 10 as described in that paper, as the finding for the plaintiff can be motivated either by desire 3 from Table 1, as *Keeble* was engaged in a profitable enterprise, or by a desire expressing protection of property rights. These alternative interpretations of *Keeble*, could be added to the framework: in Figure 3 we have added the first of them as Arg10, making attack 10. We do not represent the second challenge here as we have not represented any beliefs or desires relating to property.

This now completes the final framework and so we can deduce, with respect to each of our various agents, whether the plaintiff has remedy or not. L, who accepts Arg3, and gives prime importance to public benefit will use Arg6 to determine his decision. A, who also gives primacy to public benefit, but rejects the facts on which Arg6 is ultimately based will use Arg8. B rejects both Arg6 and Arg8 on factual grounds, and so accepts Arg7, and finally T accepts Arg8 as it is the only argument grounded on a value of which the law should take note.

5. RELATING OUR ARGUMENTS AND THE OPINIONS

In this section we will return to the opinions summarised in section 3, and relate them to the various components of the argumentation frameworks produced in the previous section. We begin by relating the arguments and attacks put forward by T and L in these frameworks to the opinions of Tompkins and Livingston. We will also need to consider the arguments of A at level three, since these are referred to by Tompkins in order to be rejected. At level three, A can be seen as the representative of the hunting aficionado, and his arguments reflect those that we might expect Post, or his counsel, to advance. We do not expect to be able to reflect the structure of the opinions, nor, of course, the extraordinary language used to deliver them, but we do hope to identify the reasoning elements corresponding to T1-8 and L1-5.

We will begin by considering the opinion of Tompkins. We will proceed top down, as this corresponds most closely to the structure of that opinion. Therefore, consider first Figure 3. Tompkins must primarily dispose of alleged precedent cases, represented in Figure 3 by Arg8. He first dismisses a number of cases as irrelevant (T3) and distinguishes *Keeble* (T5). Since we do not know the cases referred to in T3 or which argument they were supposed to support

we have not represented them here. The attacks on the interpretation of *Keeble* in T5 are represented by Arg10. Once the alleged precedent has been dismissed, Arg8 can be eliminated by denying that its value is a proper concern (V1 in Figure 3). This corresponds to T7, "no injury or damage for which a legal remedy can be applied". With Arg8 eliminated, the question turns on whether the premises of Arg6 or Arg7 are accepted. This is the question expressed in T1, and which is answered in the framework of Figure 2.

In the framework at level 2, T adopts only Arg5, that the law is clear that where there is no possession there should be no ownership. That the law is clear on this point and that there are neither cases nor authorities to suggest that pursuit of a wild animal may constitute ownership, is the point of T2 in Tompkins' opinion. The conclusion that mere pursuit cannot count as ownership is explicitly expressed at the end of T4. The purpose motivating Arg5 is expressed in T6, "for the sake of certainty".

This relates all seven components of Tompkins' opinion to our agent based account. T1 states the choice to be made at level 3, T2 and T4 provide the factual basis of Arg5, which is then motivated by the value supplied in T6, and which leads to a denial of a premise in Arg6. T3, T5 and T7 remove unfavoured arguments from level three. Tompkins, like T, has no need to descend to the issues raised at level 1.

Turning now to Livingston, he first agrees with Tompkins' view of level three (L1). L2 seems to endorse the opinion that the case should never have come before a court, and suggests that in a tribunal of sportsmen, Arg8 would be followed. In a court, however, clarity of law is important, and we take this an acceptance of the force of Arg5, which is motivated by a desire to reduce the potential for these matters to be litigated. Livingston's main argument is Arg1, stated and motivated in L3, to kill foxes "is allowed to be meritorious, and of public benefit", the value being expressed again at L5. L4 is concerned to argue that the court may make the law. It is this which expresses the preference of public benefit over less litigation, which is necessary if Arg3 is to succeed over Arg5. He suggests that the public benefit was not recognised by Justinian only because fox hunting was not then in fashion. Had it been, "the lawyers who composed his institutes would have taken care not to pass it by, without suitable encouragement".

Tables 4 and 5 summarise this discussion by listing the components of the argumentation framework, together with the agent that introduced them, and the section of the opinion which they represent. These tables show that each of the sections of the opinion can be linked to a component in the framework, with the exception of T3 and L2. T3 is similar to T5, but is omitted because, unlike *Keeble*, we do not have sufficient information about the cases dismissed as irrelevant to represent them. L2 is something of an aside, expressing sympathy with Arg8, whilst recognising that it cannot prevail over Arg7 in a court of law since for L, consideration of public benefit is proper to level two.

Of the arguments in the frameworks, \neg MI from level three is omitted, as are Arg4 and \neg Arg2 from level two and all except Arg1 from level one. \neg MI and Arg4 are proposed only by B and so represent a point of view which emerged after the decision. Similarly \neg Arg2, although attributed to L, appears only in order to attack Arg4. At level one, in the actual case no challenge was made to Livingston: again the arguments reflect later discussions. Thus all the reasoning moves in the framework that address concerns that arose at the time of the case are reflected in the opinions.

Note that Tompkins confines his considerations to levels two and three, whereas Livingston, who needs to argue instrumentally, must start at level one with a discussion of the way of the world. Our

Table 4: Arguments introduced (or mentioned if starred) in opinions.

Argument	Agent	Opinion Section
Arg10	T	T5
Arg9	A	T7*
Arg8	A	T5*
Arg7	T	T1
Arg6	L	L1
Arg5	T	T2, T6
Arg3	L	L4
¬Arg3	T	T4
Arg1	L	L3, L5
V1	T	T7

Table 5: Attacks made (or mentioned if starred) in opinions.

Attack	Attacker	Attacked	Agent	Opinion Section
10	Arg8	Arg7	A	T7*
7b	Arg7	Arg6	T	T1
1a	¬Arg3	Arg6	T	T4
16	V1	Arg8	T	T7
10	Arg10	Arg8	T	T5
11a	Arg3	Arg5	L	L4

other two agents operate mainly at levels one and three, reflecting the fact that they are not producing essentially legal arguments. A disagrees with L about the facts of the world (not the facts of the case), suggesting that fox hunting does nothing to reduce the fox population. At level 1 he argues for a sense of what is fair over the legal question which Tompkins addresses. B argues from a moral rather than a legal perspective, using a general moral value at level one and a coloured interpretation of the facts of the case at level three.

Since [12], in AI and Law discussion of *Pierson* and *Keeble* has also mentioned *Young v Hitchens*, 1 Dav and Mer. 592Q.B. 6060 (1844), a case where a commercial fisherman was interfered with by a competitor who managed to intercept the fish he was on the point of landing. We should perhaps also say something about this case. Here the fact that Young was engaged in commercial fishing rather than sport brings desire 3 from Table 1 into the question and so allows this to motivate an argument equivalent to our Arg8 in terms of economic benefit, and makes *Keeble* much more plausible as a precedent. It appears that Tompkins may not have dismissed the interference in the terms he did were there a question of financial damage. On the other hand, level one will be entirely different in *Young*. In particular, although Young does suffer financial damage, the public do not suffer, since they can purchase the fish from Hitchens as well as Young. Thus there is no argument to ground Arg3 at level 2: commercial fishing is neither encouraged nor discouraged by finding for the plaintiff, since both plaintiff and defendant are engaged in the activity. Thus although the question of economic benefit can be raised, it cannot motivate an argument at this level. *Keeble* is structurally rather closer to *Pierson* at level one: there the actions of the defendant do serve to reduce the supply of ducks to the public, but the activity of *Keeble* had a direct economic benefit which provided a stronger reason to accept the argument than was available to Post. The question in *Young* therefore turns on whether the strengthened Arg8 defeats Arg7. Arg6 does not appear since Arg3 is not available as its premise. It seems from

the account of Patteson’s opinion given in [12] the court was reluctant to pronounce on what constituted unfair competition. Accepting Arg8 over Arg7 in *Young* would effectively denounce Hitchen’s actions as unfair.

6. RELATED WORK IN AI AND LAW

The work in this paper draws on a number of themes from AI and Law. In this brief section we will make some pointers to this foundational work.

Argument schemes, most notably that of Toulmin [22], have been used in a number of AI projects, of which the earliest were [17] and [16]. Toulmin’s scheme is quite general, but is concerned with the inference of facts rather than practical reasoning. In its original form, it permits only one kind of attack, based on an argument for the negation of the claim. Extensions, such as used in [6], allowed for undercutters, by adding elements to the scheme and for premise defeat by allowing chaining of the schemes. Critical questions have been used explicitly in connection with other argument schemes, especially the schemes from witness testimony and the scheme from expert opinion, in e.g. [25] and [20]. Again, however, these concern inference of facts: the explicit use of argument schemes to justify actions was used in [15]².

The use of values derives from the important paper [12] which also included *Pierson* in the cases discussed, and was revived in a group of three papers by Bench-Capon, Sartor and Prakken written in early 2000 [1]. This strand of work is most fully described in [11]. The contribution of this paper is to use the argument scheme to relate values to arguments in an explicit way, and to construct value based arguments.

Argumentation frameworks, in the style proposed by [14] were first used to explore the dialectic status of groups of arguments in [21]. They were used to model a set of cases including *Pierson* in [7], based on the analysis of [10]. The same cases were also modelled using Value Based Argumentation Frameworks in [9]. In this work the structure of arguments was left entirely abstract, [7], [9], or seen as a sequence of inferences [21], with the standard attacks of rebuttal and undercut. Instantiating the arguments with a scheme designed for practical reasoning and generating attacks through the critical questions on this scheme is new to this paper.

7. CONCLUDING REMARKS

In this paper we have used an approach to modelling practical reasoning and persuasive argument to reconstruct the reasoning in a well known legal case. Our aims in so doing were two fold: to show the feasibility of construing legal argument in terms of our argument scheme for practical reasoning and the critical questions which can be posed against instantiations of it, and to provide a domain to exercise our proposals to realise such debates as a multi agent system with the different agents representing divergent beliefs, desires and values. We believe we have been successful in both these aims.

One interesting feature to emerge from the debate is the layered nature of the process: instrumental arguments about the world provide premises for arguments about the application of legal concepts, which in turn form the basis for the resolution of the legal questions relating to the case. These levels constantly appear in work on case based reasoning in AI and Law. For example, consider IBP [13]. In IBP level 3 is represented by structuring the problem in terms of issues. Below this, at level two, each issue is considered separately in terms of the factors relevant to the issue.

²Greenwood was the maiden name of the first author of this paper.

When each issue has been determined separately a decision as to the case is made at the issue level. There is no level one in IBP, but here considerations would relate to whether a factor was relevant to an issue and whether a factor applied in a given case. These considerations are already accounted for in the domain analysis. An interesting topic for future work would be to investigate further the relations between our work and work such as IBP.

Looking towards practical realisation, the major difficulty seems to arise from the extensive knowledge representation required to model the instrumental reasoning at level one. It is difficult to imagine this kind of knowledge being available in advance of the case. For a particular case, however, it is less difficult to construct the fragment required to drive the reasoning in a particular circumstance. Thus it would be possible to analyse particular cases in this way, as we have done here. Such an analysis provides a useful way of identifying the possible points of contention, the differences in beliefs, desires and values which motivate them, and the level at which the disagreements occur.

Acknowledgements

Katie Atkinson is grateful for support from the EPSRC. Trevor Bench-Capon and Peter McBurney are grateful for partial support received from the European Commission, through Project ASPIC (IST-FP6-002307). We are also grateful to the anonymous reviewers for their helpful comments and suggestions.

8. REFERENCES

- [1] Special issue in memory of Don Berman. In C. Hafner and E. Rissland, editors, *Artificial Intelligence and Law*, volume 10 (1-3), pages 79–133, 2002.
- [2] K. Atkinson, T. Bench-Capon, and P. McBurney. Attacks on a presumptive argument scheme in multi-agent systems: pre-conditions in terms of beliefs and desires. Technical Report ULCS-04-015, Department of Computer Science, University of Liverpool, UK, 2004.
- [3] K. Atkinson, T. Bench-Capon, and P. McBurney. Justifying practical reasoning. In F. Grasso, C. Reed, and G. Carenini, editors, *Proceedings of the Fourth International Workshop on Computational Models of Natural Argument (CMNA 2004)*, pages 87–90, Valencia, Spain, 2004.
- [4] K. Atkinson, T. Bench-Capon, and S. Modgil. Value added: Processing information with argumentation. In *Submitted to: Second International Workshop on Argumentation in Multi-Agent Systems (ArgMAS 2005)*. In submission.
- [5] T. Bench-Capon. Knowledge based systems applied to law: A framework for discussion. *Knowledge Based Systems and Legal Applications*, pages 329–342, 1991.
- [6] T. Bench-Capon. Geof staniford: Plaid: Proactive legal assistance. In *Proceedings of the Fifth International Conference on AI and Law (ICAIL 1995)*, pages 81–88, New York, NY, USA, 1995. ACM Press.
- [7] T. Bench-Capon. Representation of case law as an argumentation framework. In T. Bench-Capon, A. Daskalopoulou, and R. Winkels, editors, *Legal Knowledge and Information Systems, Proceedings of Jurix 2002*, pages 103–112. IOS Press: Amsterdam, 2002.
- [8] T. Bench-Capon. Persuasion in practical argument using value based argumentation frameworks. *Journal of Logic and Computation*, 13 3:429–48, 2003.
- [9] T. Bench-Capon. Try to see it my way: Modelling persuasion in legal discourse. *Artificial Intelligence and Law*, 11 (4):271–87, 2003.
- [10] T. Bench-Capon and E. Rissland. Back to the future: dimensions revisited. In B. Verheij, A. Lodder, R. Loui, and A. Muntjewerff, editors, *Proceedings of JURIX 2001*, pages 41–52, Amsterdam, The Netherlands, 2001. IOS Press.
- [11] T. Bench-Capon and G. Sartor. A model of legal reasoning with cases incorporating theories and values. *Artificial Intelligence*, 150 (1-2):97–143, 2003.
- [12] D. H. Berman and C. D. Hafner. Representing teleological structure in case-based legal reasoning: the missing link. In *Proceedings of the Fourth International Conference on AI and Law (ICAIL-1993)*, pages 50–59, New York, NY, USA, 1993. ACM Press.
- [13] S. Brüninghaus and K. D. Ashley. Predicting outcomes of case-based legal arguments. In *Proceedings of the Ninth International Conference on AI and Law (ICAIL-2003)*, pages 233–42, New York, NY, USA, 2003. ACM Press.
- [14] P. M. Dung. On the acceptability of arguments and its fundamental role in nonmonotonic reasoning, logic programming and n-person games. *Artificial Intelligence*, 77:321–357, 1995.
- [15] K. Greenwood, T. Bench-Capon, and P. McBurney. Towards a computational account of persuasion in law. In *Proceedings of the Ninth International Conference on AI and Law (ICAIL 2003)*, pages 22–31, New York, NY, USA, 2003. ACM Press.
- [16] L. S. Lutomski. The design of an attorney’s statistical consultant. In *Proceedings of the Second International Conference on AI and Law (ICAIL 1989)*, pages 224–233, New York, NY, USA, 1989. ACM Press.
- [17] C. C. Marshall. Representing the structure of a legal argument. In *Proceedings of the Second International Conference on AI and Law (ICAIL 1989)*, pages 121–127, New York, NY, USA, 1989. ACM Press.
- [18] L. T. McCarty. An implementation of eisner v macomber. In *Proceedings of the Fifth International Conference on AI and Law (ICAIL-1995)*, pages 276–286, New York, NY, USA, 1995. ACM Press.
- [19] L. T. McCarty and M. S. Sridharan. A computational theory of legal argument. Technical Report LRP-TR-13, Computer Science Department, Rutgers University, 1982.
- [20] H. Prakken, C. Reed, and D. Walton. Argumentation schemes and generalizations in reasoning about evidence. In *Proceedings of the Ninth International Conference on AI and Law (ICAIL 2003)*, pages 32–41, New York, NY, USA, 2003. ACM Press.
- [21] H. Prakken and G. Sartor. A dialectical model of assessing conflicting arguments in legal reasoning. *Artificial Intelligence and Law*, 4(3-4):331–368, 1996.
- [22] S. Toulmin. *The Uses of Argument*. Cambridge University Press, Cambridge, UK, 1958.
- [23] A. Trollope. *The American Senator*. Oxford University Press, Oxford, UK, 1986.
- [24] A. Valente. *Legal Knowledge Engineering: A modelling approach*. IOS Press, Amsterdam, 1995.
- [25] B. Verheij. Dialectical argumentation with argumentation schemes: An approach to legal logic. *Artificial Intelligence and Law*, 11 (2-3):167–195, 2003.
- [26] D. N. Walton. *Argument Schemes for Presumptive Reasoning*. Lawrence Erlbaum Associates, Mahwah, NJ, USA, 1996.
- [27] M. J. Wooldridge. *Reasoning about Rational Agents*. MIT Press, Cambridge, MA, USA, 2000.